

Measurement Systems

WLT-800

General Specifications:

- Capacity: Up to and including 1000 CFH class meters (excluding Sprague & Rockwell 1000's)
- Thermostatically controlled water heater
- Circulating pump
- Water filter
- Rotating meter stand to view meter a full 360° while standing in front of the tester

Requirements:

- Power: 120vac at 30 amps
- Compressed Air Supply: 90 psi at 5 CFM
- Water Supply: standard hose connection
- Water Drain: standard hose connection

Dimensions: (Height x Width x Depth)

- 83in x 23in x 47in

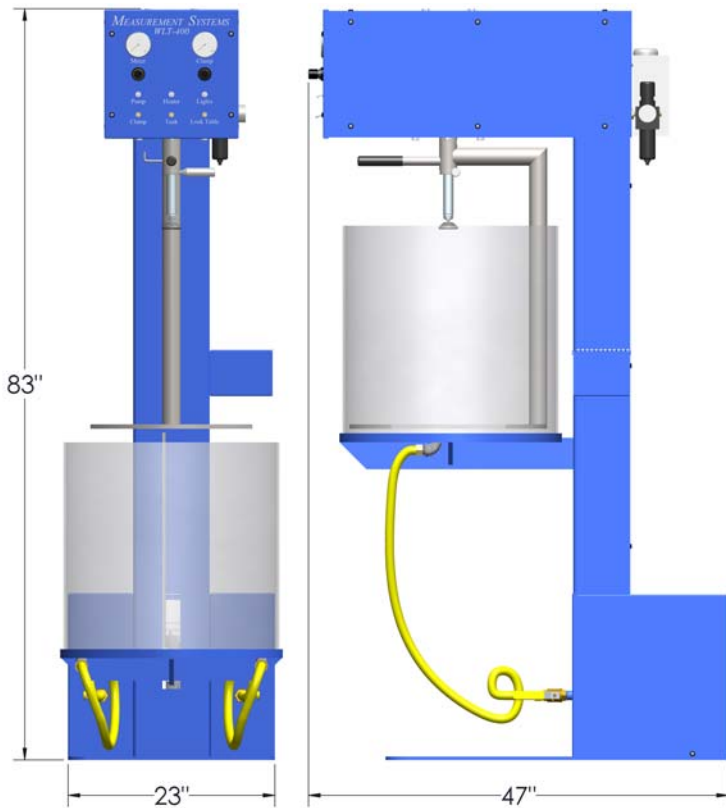

Con Edison WLT-800 Installation

Current Customers:

PGW (Philadelphia Gas Works) – (4) WLT-400
ONEOK – (2) WLT-400 & (1) WLT-800
Con Edison – (1) WLT-400 & (1) WLT-800
Columbia Gas of Massachusetts – (2) WLT-400
Washington Gas – (1) WLT-400

NYSEG – (1) WLT-400
National Fuel – (2) WLT-400
IMAC Systems – (1) WLT-800HP

6217 Stoney Hill Rd.
New Hope, Pa 18938
(215) 862-3090 Fax (215) 862-3449
Email SalesInfo@MeasurementSystems.com